

COMPLETED EINSTEIN GENERAL THEORY OF RELATIVITY (CGTR)

Nimit Theeraleekul B. Eng. (Communication)
(February 28, 2007, 2nd. revised June 1, 2009)

Abstract: Einstein general theory of relativity (GTR) has been criticized for their philosophic problems (both which came from STR and its own problems), **despite of their predictability and accuracy**. Indeed all the problems could be eliminated by using “Vacuum Mechanics” i.e. the mechanism of vacuum medium!

Content: 1) Introduction. 2) **Mechanism of gravity**. 2.1) Why do masses attract each other? 2.2) How do masses attract each other? 3) **Philosophy behind space-time**. 3.1) Newtonian space-time vs. Minkowskian space-time. 3.2) Vacuum medium space-time. 4) **Physical meaning of space-time curvature**. 4.1) A new view of curved surface. 4.2) A better view of curved space-time. 5) Modification of GTR. 5.1) Einstein tensor is vacuum tensor. 5.2) **Return of cosmological constant**. 6) **Solution to some crucial problems**. 6.1) Problem with speed of gravity wave. 6.2) Some others remaining problems. 7) **Vacuum medium universe – a better view of our universe**. 7.1) Fulfilling the cosmological principle. 7.2) What is a hypersphere? 7.3) The origin of universe. 7.4) **Our universe is closed!** 8) Conclusion. 9) References.

1) Introduction. This article is the third expanding part of the original article “**Vacuum mechanics a New Approach to the Theory of Everything**” (VMTE) [1]. Four most important theories are involved in VMTE; Maxwell electromagnetic field theory (EMT), Einstein special theory of relativity (STR), Einstein general theory of relativity (GTR) and Quantum mechanical theory (QMT). Because what has been talked in VMTE is rather a philosophical one, so the first two articles have been expanded with the titles “**Completed Maxwell electromagnetic field theory**” (CEMT) and “**Completed Einstein special theory of relativity**” (CSTR) respectively [1]. Here in this paper, GTR will be expanded to “**Completed Einstein general theory of relativity**” (CGTR) in a more scientific detail. And because CGTR is related to VMTE and CSTR, so we have to refer to them quite often in this article, so they are summarized as below. (For more detail please refers to the reference.)

In VMTE we have started with the fundamental hypothesis that “**Vacuum medium is the fabric structure of vacuum space**”. And it was proved that vacuum space is not the conventional empty vacuum space; instead it is **vacuum medium space!** In more detail it is the **privileged absolute reference frame** of a continuous isotopic homogenous medium and having a peculiar mechanical property; it is very thin in mass density which is **permeable by all matters almost without any observed resistance!**

“**Electrons and protons are tiny black holes**” is the consequence hypothesis, and they were proved to be the “**condense**” of **vacuum medium**. Both of them are the two elementary particles which form to be **all kinds of the material matters existed in the universe!** So our universe is composed of material matters immerge in a huge volume of vacuum medium.

Vacuum mechanics – a new conceptual mechanics. It is the **mechanism of vacuum medium** i.e. the action of vacuum medium, or of condensed vacuum medium, and the interaction between them, which is **responsible for all natural phenomena in our universe!** Latter we will see how this vacuum mechanics is the key for solving the philosophic problems in GTR.

(2)

For CSTR, we have derived the **Lorentz transformation by using vacuum medium as the privileged reference frame** and so we could understand its physical meaning! Then we have showed that **“the increasing mass”** of the moving object **was due to the inertial resistance of vacuum medium** (not the increasing of the material mass of the object itself).

And we showed that **“time dilation”** of the moving frame **was the slowing of the measuring clock’s mechanism** (due to the inertial resistance of vacuum medium) and we have called it as **“relativistic clock”**. Also **there is no real “length contraction”**, it is a **relative length** which occurred in STR for trying to keep the constancy of light velocity referenced to the moving observer! Finally we have shown how to solve the unsolved problem in classical mechanics (as STR does), but with a more rational and understandable way.

Now to improve GTR to be CGTR, we will first point out detail of the **philosophic problems** (i.e. the idea that showing how it works) of the main parts that involved; the principle of relativity, space, time, mass and gravity. Next **using the new propose concept of vacuum mechanics to solve the problems**. Finally what we got after modification is a more rational and understandable GTR that is CGTR!

2) Mechanism of gravity. Sir Isaac Newton had first provided us with his Universal law of Gravitation via the formula (1) below, which state that two mass attract each other with the force F that directly proportional with their masses m_1 and m_2 , and inverse proportional to square of the distance r between them.

$$F = G \frac{m_1 m_2}{r^2} \dots (1), \quad \varphi = GM / r \dots (2), \quad G_{\mu\nu} = kT_{\mu\nu} \dots (3).$$

But Newton said nothing about **“why and how masses attract each other”**. So modern physicists try to explain it via gravitational field concept. And according to the formula (2) that the gravitational potential φ at any point around a source mass M is direct proportion to the mass over the separate distance r . This seems to be okay, but why and how? We could not visualize the working process; it is just an ad hoc solution.

Lastly while Einstein said that **gravity is the manifest of curve space-time** according to his famous field equation (3) (where $G_{\mu\nu}$ is Einstein tensor $T_{\mu\nu}$ is energy-momentum tensor and k is a coupling constant), but why and how mass and energy cause space-time to curve is unexplained! **Armed with the concept of the mechanism of vacuum medium i.e. vacuum mechanics**, we are now going to see **“why and how masses attract each other”** together.

2.1) Why do masses attract each other? As mentioned about VMTE in the first section that **“space was created out of vacuum medium energy”** or we could say that vacuum medium is the fabric structure of vacuum space. And the most important special intrinsic property of vacuum medium is that **every infinitesimal part of them attracts each other with their own intrinsic gravitational force** (contraction force)!

Also in VMTE we have verified that **“electrons and protons are tiny black holes of condensed vacuum energy”**. (We could visualize them as two sizes of small solid spheres of the very concentrated vacuum energy; electron: a smaller one, proton: a bigger one). So electron and proton can attract each other (also with the surrounding vacuum medium space) with their **black hole forces**, a much stronger attractive force than normal gravity (which created by masses attraction). Actually these black hole forces are the familiar forces **known as electrostatic or Coulomb forces!**

(3)

Now we knew that **all the matters in the universe compose of two elementary charge particles i.e. electron and proton**. And because both of them are tiny black holes of condensed vacuum medium (which have its intrinsic gravity property), **so it is inevitable that gravity is also the property of material masses**. Anyway we have to make clear that the gravity between masses is different from the gravity inside masses. **All attraction forces between any component parts within mass are black hole forces, while the attraction forces between masses are normal gravitational forces!**

(Please note that **all size of tiny black holes always attracts each other**. There is only one special case in which the same size (same type of charge) will repel, that is when both of them closing to each other at a certain distance. This is because of the repulsive stress in the vacuum medium between them is dominated (please see detail in VMTE). **So from now on when talking about the interaction between charged particles we will refer only to attractive force, which is the force between electron and proton!**)

Now to see the action of **black hole force** (or Coulomb force) **within masses**, first we have to start with the most simple atom i.e. **hydrogen atom**. We know that it was formed by electron and proton attract close together by black hole force. But notice that both particles are still **not attach together** because the existing of vacuum medium between them. To displace the medium between, some **external additional forces** was used. This extra force must be strong enough to tear off the medium which was called **weak force!** Next is **the nucleus of helium atom** which composes of two protons and two neutrons. From the former paragraph we could see that two protons will repel each other when they are closing together enough, but not yet attach together. So some **external additional force** must be used to overcome the repelling force, and this extra force (a short range force) was called as **strong force!**

Next talking about **the attraction force between atoms within a molecule, and between molecules**, are they also black hole force? Indeed they are; all categories of bonding i.e. Val der Waals or molecular bonding, ionic bonding, covalence bonding, metallic bonding and hydrogen bonding **all are electrostatic forces [2] i.e. black hole force!** (Please be reminded that mass is not directly attracted each other but working via vacuum medium, in which there also has internal attraction force within vacuum medium itself). In conclusion, we may say that "any kind of material masses compose of billions of tiny black holes holding together with black hole force, **so this is the reason why masses attract each other!**"

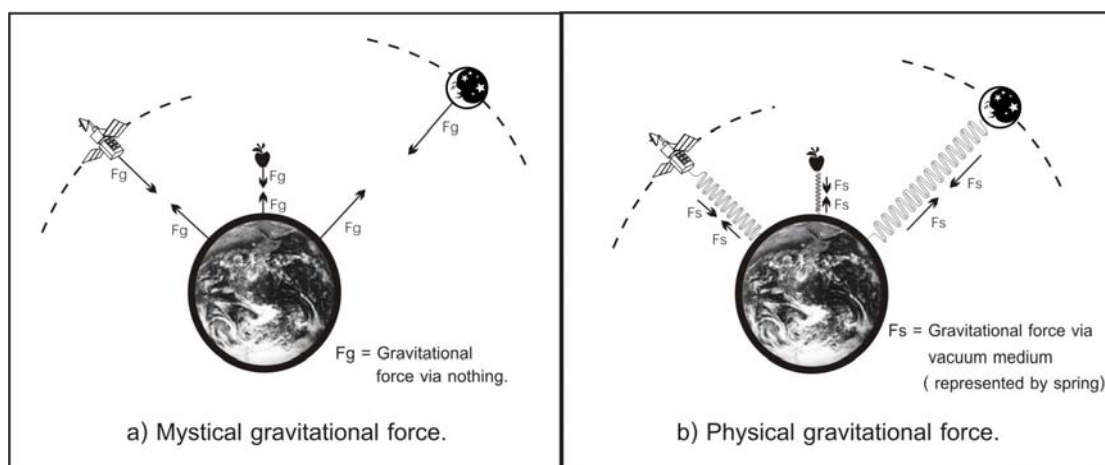

Figure 1 Attraction mechanism between two masses.

(4)

Finally, before finding out “**how masses attract each other**” we have to point out one of the most crucial concept about the action of force, that is “**any interaction of forces between two masses which is not a direct contact action, there must be some kind of mediums acting as a transmitting mechanism for the force**”! For example when we want to pull an object we must use some material such as rope as the transmission of force. And even within (or between) atoms of rope’s material we would found that there are filled with vacuum medium which acting as force transmitter.

Unfortunately in our daily life, **we could not see vacuum medium**, while we **all are familiar to gravity**, so it seem that **no medium is required** as in diagram fig.1 (a). And when we look at diagram1 (b) for the first time, **it would look crazy!** But after considering for a second we would found that **it was crazier if there is nothing pulling between them.** Why? Because **gravity is physics** (science of nature) **not mystic** (unscientific) and we will return to talk more detail next.

2.2) How do masses attract each other? When physicists use gravitational field concept to explain the attraction force between masses, they are wondered why it is so similar to electrostatic field concept. And **they seem to believe that they are different thing.** Armed with the concept of vacuum mechanics, we could understand without difficulty that **both fields are the same thing; it is the contraction force field (internal stress) in vacuum medium!**

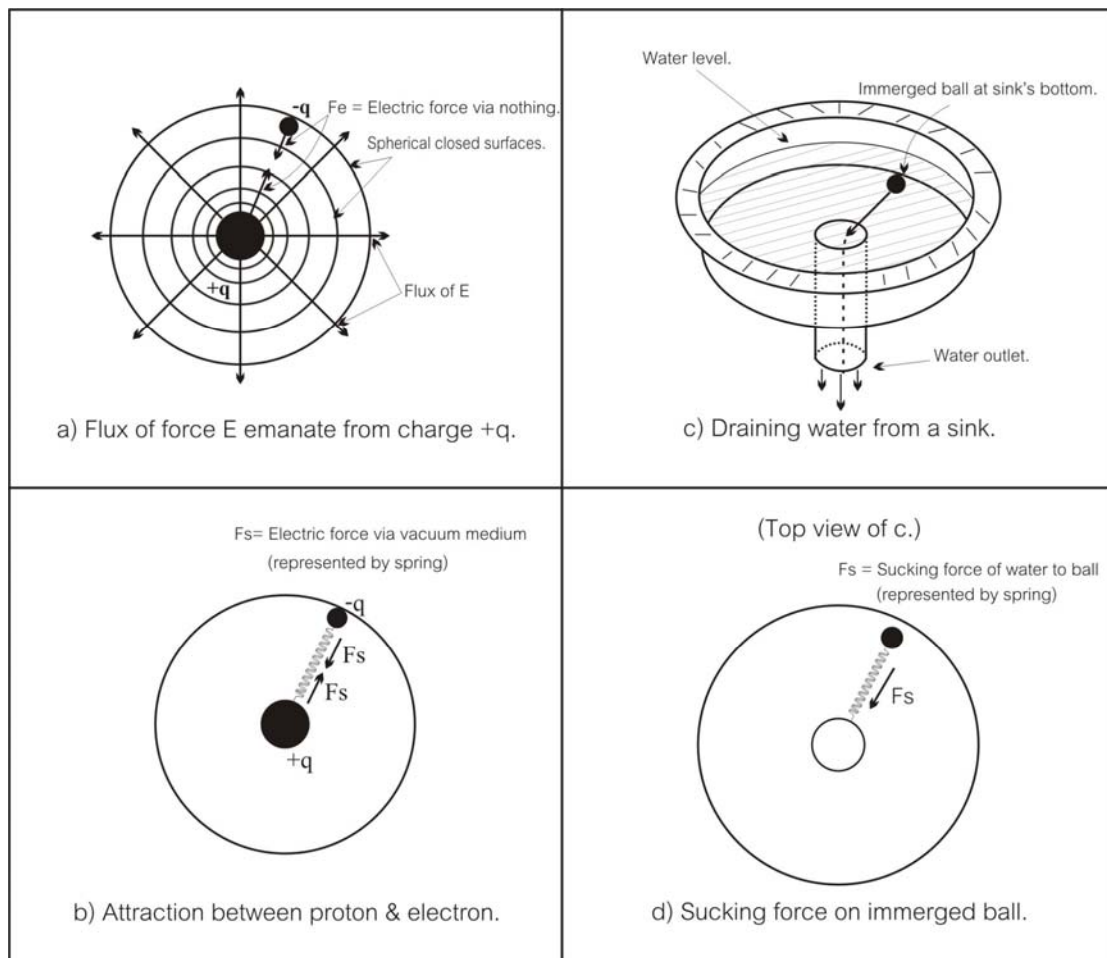

Figure 2 Attraction mechanisms between two charges.

(5)

Before seeing “how masses attract each other”, it is easy to start with “**how charges attract each other**” by using the idea of “the flux of E (electric field)” explained by Richard P. Feynman [3].

According to diagram 2(a), flux of E emanate from charge +q (proton) in a spherical shape (shown in circle) around the charge, and at any distant r from center of charge,

$$E = \frac{1}{4\pi\epsilon_0} \frac{q}{r^2} \dots (4). \quad (\text{where } \epsilon_0 \text{ is the permittivity constant}).$$

Actually E is the force that will act on a unit charge placed anywhere in the electric field E. So the total flux of force from charge +q is as follow.

$$\text{Total flux of force through closed surface} = \oint E_n da = \left(\frac{1}{4\pi\epsilon_0} \frac{q}{r^2} \right) (4\pi r^2) = \frac{q}{\epsilon_0} \dots (5).$$

Note, even “flux” means “flow” but “flux of force” does not mean “flow of force”, instead it means “**emanating of attractive force**” via the internal stress of vacuum medium” around the charge sphere +q. Or we could say that at a distance r from charge +q, there is an attractive force (a contraction stress in vacuum medium) per unit area equal to $(1/4\pi\epsilon_0).q/r^2$. And if -q charge is placed at r, then **the attractive force per unit area is equal to $(1/4\pi\epsilon_0).(+q)(-q)/r^2$ as showing as the contraction spring** in fig.2 (b).

And to make it easy to understand “how charges attract each other”, look at diagram 2(c) and 2(d) for analogous concept. **While water is draining from sink, the tiny ball immersed in water was sucked via water and moving forwards the drain!**

Now in the similar way, we could calculate **the total flux of force from the normal mass M** in fig.1 (a) (Readers could found the detail in “Gauss’s law for the gravitational field” [8].) as follow.

$$\text{Total flux of force through closed surface} = \oint g_n da = G(M/r^2)(4\pi r^2) = 4\pi MG \dots (6).$$

[Where $g_n = G(M/r^2)$... (7) is the force of the gravitation field which acts at a unit mass placed at the surface of the sphere with a radius r and G is the gravitational constant. (g is the same thing as the acceleration of a unit mass.)]

To interpret the meaning of formula (6) we have to look at its unit, which is force · area / mass (newton·meter² /Kg.). So the formula say that **M Kg. of mass creates gravitational force multiply by the enclosed area is equal to $4\pi MG$ (newton·meter²) around the mass sphere via the internal stress of the surrounding vacuum medium.** Or we could say that, at any point r from the mass M there is a gravitational force act at a unit mass placed there **per unit area = $G.M/r^2$** . And **if mass m was placed at r then the gravitational force between M and m per unit area = $G.Mm/r^2$** , which shown as **the contraction springs** in fig.1 (b).

(6)

Now we come back to explain more detail about diagram fig.1 above. For diag.1 (a), **when considering it scientifically** we would found that **it is mystic**. The reason is because there is no mechanism for gravity (for explain how it work) so it is **a supernatural phenomenon!** Instead if we accept that there are infinite numbers of **unseen** spherical concentric shells of internal stress in vacuum medium around the earth. **Then each shell represents different value of gravitational force which is the manifest of internal stress in vacuum medium.**

While the closer shells to the earth mean the stronger of the gravitational force, and the far away shells mean the weaker of the gravitational force according to formula (7). So if we understand the mechanism which just explained, **then the mystic view of the unseen gravitational force is not mystery anymore!** Anyway, for someone who is not familiar with **the unseen "internal stress in some material medium"** it is still difficult to visualize. So the contraction spring in diag.1 (b) would give a better view, **even though it may look strange and unfamiliar to us!**

Finally we come to the conclusion; in this section we have explained the mechanism of gravity which is the action of the internal stress in vacuum medium between masses. While in the former section we have shown that mass which was formed from billions of tiny black holes (condensed vacuum medium), so it also has gravity as its own property. Then by using the concept of vacuum mechanics, we could say that **"masses create gravity and manifest it via the internal stress in vacuum medium"**, O K?

3) Philosophy behind space-time. All of us live in the world or actually in the universe that involved with "space" and "time". Then everything, all natural phenomena and human activities can not be separated from space and time. Nowadays we have two types of them; the first one is **classical Newtonian space-time** and another one is relativistic **Minkowskian space-time**. Anyway **it is interesting to note that both concepts of space-time still have their own problem until now!** So we have to clarify them first before we could improve and got a complete GTR.

3.1) Newtonian space-time vs. Minkowskian space-time. Let's start with Newtonian space-time with absolute three dimensions spatial space and one universal time. It is the same thing as Euclidean space in which the square of Euclidean "distance" between two adjacent Cartesian coordinates is

$$\sigma^2 = (x_1 - x_2)^2 + (y_1 - y_2)^2 + (z_1 - z_2)^2, \quad t_1 = t_2 \dots\dots (8).$$

Note that each spatial distance term and time interval of (8) is invariant (constant).

But according to STR, where the constancy of speed of light (referenced to any moving initial observers) was used to link these three dimensions of space and one dimension of time, and what we got is a four dimensions space-time called **Minkowskian space-time**. And the square of space-time "interval" between two events is

$$s^2 = c^2 (t_1 - t_2)^2 - (x_1 - x_2)^2 + (y_1 - y_2)^2 + (z_1 - z_2)^2 \dots\dots (9).$$

Note that each spatial distance and time interval term in the right hand side of (9) is not invariant (not constant).

(7)

Now by comparing Newtonian space-time with Minkowskian space-time we would find that in the former, **space is absolute (constant) and independent from time**, while in the latter **space and time are dependent**. And notice that **both of them are the concept of empty space not physical space**. There is a weak point about universal time in Newtonian space-time; that is the concept of instantaneous action at a distance. It means that **any action of force or traveling of light signal occur with infinite speed** which is unacceptable. But this is what it should be because it corresponds to Newton's concept that **space is empty!** The reason is that light speed is infinite in any medium with zero density (Wave speed in any medium is proportion to square root of elasticity over density).

Minkowskian space-time also has a weak point about **the distortion of both space and time; that is there is both the time dilation and length contraction!** The reason is because Einstein mixed them by keeping "constancy of speed of light referenced to inertial moving observers" for his derivation of Lorentz transformation (Please see detail in CSTR). Up to now we have seen the problems which involved with both Newtonian and Minkowskian space-time. **So what we want now is a better view of space-time which has no side effect mentioned above; that is "Vacuum medium space-time".**

3.2) Vacuum medium space-time. Based on "vacuum medium is the fabric structure of vacuum space", vacuum medium space **is a physical space not an empty one**. It is the same concept as Newtonian absolute space with universal time; the only **difference** is that vacuum medium space is a physical space not an empty as Newtonian space do. This means that **the distance between any two points in space is constant**, while the universal time means **at any instant, time is the same and it flows evenly everywhere**. So what was defined as the continuum of four dimensions space-time, **actually it is the continuum of three spatial spaces at any instant time!**

Another thing that vacuum medium space-time **different** from Newtonian space-time is that **speed of any action or speed of light signal is c, not infinity** (according to vacuum mechanics, any disturbance in vacuum medium propagate with light speed c). And when measurement was made by a moving observer referenced to vacuum medium, **space and time could be mixed by using the constancy of light speed to be vacuum medium space-time without any distortion!** So every term in equation (9) is invariant.

Below is **how the dynamics of a moving inertial frame work in vacuum medium space-time**, which is worked according to **Lorentz transformation!** In the diagram of fig.3, a light source was placed at the origin O of the stationary absolute privileged vacuum medium reference frame S at time $t = x = y = z = 0$. Then light signal propagates radial outward as a sphere. And at any instant time t_p , what we got for the event at $P(x_p, y_p, z_p, t_p)$ is the sphere formula;

$$s_p^2 = c^2 t_p^2 - x_p^2 + y_p^2 + z_p^2 = 0 \quad \dots\dots (10).$$

Now, let us place the light source at the origin O' of a moving frame S' (referenced to vacuum medium rest frame). Again when O' is at O and at $t = t' = 0$, while light source is start emitting, S' is also moving with speed v (less than c). When S' is passing P' toward Q, the emitting signal from P' will reach P at the same instant that S' is at Q. And if we consider only for the co-ordinate x, then the time t' at P' and the distance x' (distance between P' and P) **are the time and the distance according to Lorentz transformation!**

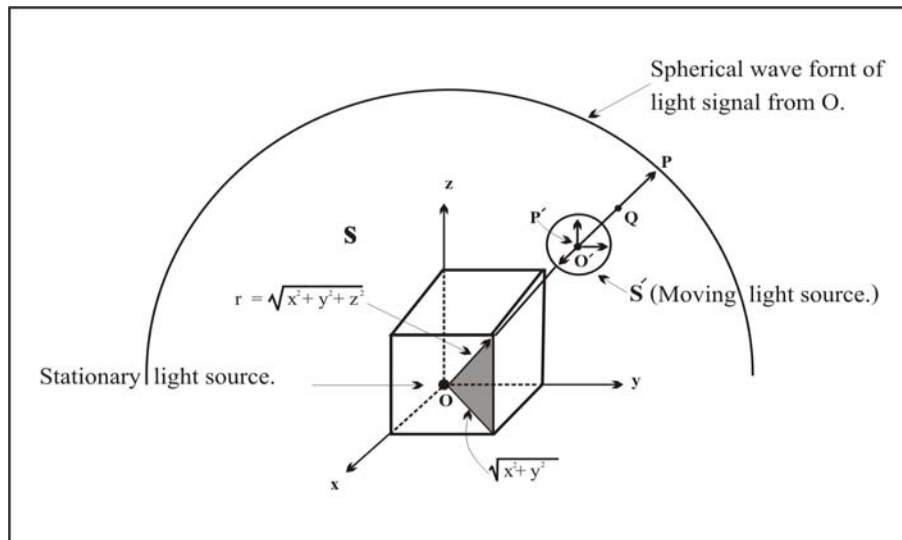

Figure 3 Vacuum medium space-time.

To see the **physical meaning** of the invariance s^2 in S defined in (9), by comparing to s_p^2 of (10) in S', we would found that

$$s_p^2 = c^2 t_p^2 - x_p^2 + y_p^2 + z_p^2 = s^2 = c^2 t'^2 - x'^2 + y'^2 + z'^2 = 0.$$

Someone may say that it is just the concept of STR that “the constancy of speed of light referenced to any moving initial observers”. But when consider the above diagram carefully we will found that, it is the emitting light signal from P' that reaches P not from Q (the actual position of S' at time t). **So it means that the constancy of light speed is reference to absolute vacuum medium space, not to the observer in a moving inertial reference frame!** That is, the propagation time of light signal from P' to P is t' , not the time from the present position Q (of S') to P. **Then there is no “true” time dilation and no “true” length contraction!**

Finally if there is **no real** time dilation and **no real** length contraction, **are proper time and proper length still necessary?** The answer is yes; because both of them are **relative values** and still useful for some propose such as Doppler Effect. Beside that we still have the **relativistic clock** instead of the conventional time dilation. And for length contraction, because it is only a **relative length**, so we must be careful **not to use the length contraction for guiding to the increasing density of mass!**

By the way, **proper quantity** was defined as **the intrinsic quantity** when measuring was done by an observer on his own reference frame. But according to STR & GTR, all reference frames are moving relative to each other. So **we could not find any “true” intrinsic quantities in our universe.** Instead according to vacuum medium space-time, we could preserve the meaning of “intrinsic quantity” because **it is only the same one true invariance measured quantity in any reference frame!**

4) Physical meaning of space-time curvature. According to GTR, our universe was built with four-dimension space-time (three spaces plus one time), but it is impossible to visualize how curve space-time is. Let's refer to a famous professor in physics nowadays, Stephen W. Hawking word [5] **"It is impossible to imagine a four dimensional space."** Or (again) referenced to Richard P. Feynman word [6] "We live in three-dimension space and we are going to consider the idea that three-dimension space is curved, we can't imagine space being bent in any direction because our imagination isn't good enough. (Perhaps it's just as well that we can't imagine too much, so that we don't get too free of the real world.)" Is this word still being true forever? **Could we understand three-dimension space being curved while we still live in the real world? For my opinion, the answer is yes we could!** So let's us find out together by starting with a two-dimension space below.

4.1) A new view of curved surface. All of us are familiar with a two-dimension curved surface such as a portion of elastic spherical surface sheet of a basket ball shown in fig.4 (a) below. After we flatten it out by making an appropriate cut where necessary, then what we got is **an incomplete flat sheet** as shown in (b). Next, we complete the cut-off parts by pulling the neighboring parts together (while keeping the sheet's thickness to be the same everywhere). Then what we got is **a completed flatten surface sheet** as in (c). Actually, we could get the flattened sheet (c) just by pressing the curved surface sheet (a). **Note that the flattened surface sheet (c) is not the same thing as a true (ordinary) flat surface in (d)** (which made from the same elastic material)! But, what is the difference?

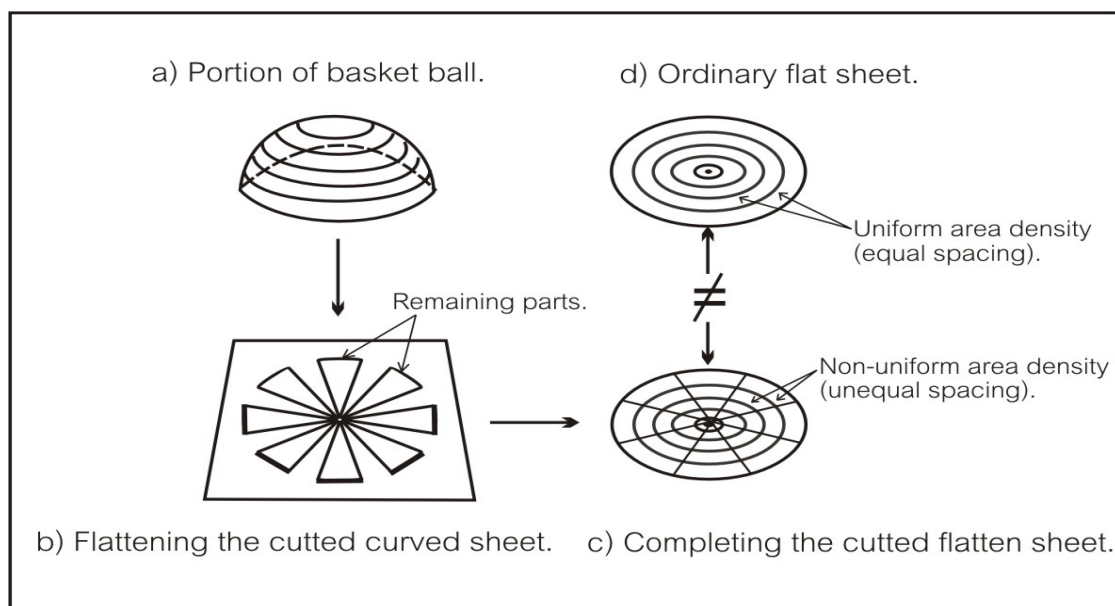

Figure 4 Comparing a curve surface with a flat surface.

The difference is that the **area density of elastic material is uniform in a true flat surface sheet (d)**, while it is **not uniform in the flattened surface sheet (c)** that is the area density vary from high density around the center to the lower density at the rim of the sheet. So the **uniformity of material density of (physical) space is the crucial points** for considering whether it is a flat sheet or a curved sheet. Then from this point of view **we may say that a curved surface sheet is a non-uniform of material density of a flat surface sheet!**

4.2) A better view of curved space-time. Now we will extend the concept “**non-uniformity of the material density in space**” from a two-dimension curved space (curve of sheet space) to a three-dimension curve space (**curve of volume space**). First we start with a simple analogy of the atmosphere which covers the surface of our earth. We know that air density is higher near the earth’s surface and decreasing to a lower density when the altitude is increasing. This non-uniform density of air was caused by the earth’s gravity which is higher near the earth’s surface and decreasing at a higher altitude. So **we could say that the atmosphere space (physical space of air) is curved.** But suppose that if the gravitational attraction of the earth to the atmosphere is the same at any altitude, then the air’s density will be uniform. **In this case we could say that the (three- dimension) atmosphere space is flat!** (Note, both the words “curve” and “flat” used for volume space came from curve and flat sheet that we are familiar, so it may leads to some confusion, doesn’t it?)

Up to now we have found that it is easy to visualize and understand “flat and curved space” by using concept “uniformity of density of the material that constitute the physical space”. So for **vacuum medium space, it is the uniformity density of vacuum medium energy that was used for considering the curvature.** But we have to be careful because there are two part of vacuum medium energy. The main part is the energy that constitutes and maintains the isotopic fabric structure of space (flat space). While the additional part is the internal stress energy in vacuum medium that occurred due to the existing of the near by mass (gravitational potential energy). To visualize the internal stress energy occurred in vacuum medium, it is easy to look at “**internal stress created in incompressible fluid such as water** when it (the water) was subjected to external force. In this condition we would found that volume of the water is not change (mass or energy density is the same as in the water without subjection to external force), but there is an additional stress energy occurred in the water!

To show formally how the concept of “non-uniformity of energy density of vacuum medium space” could explain “curved space”, we will go back to the two last paragraphs in section 2.2. There, we have said that gravitational force is the manifest of internal stress in vacuum medium space near the center of earth’s mass. While the stress in vacuum medium that closed to the mass is higher due to the stronger force of gravity, the far away part will be lesser due to the weaker gravity according to equation (7), that is $g = G(M / r^2)$.

Actually we could view the surrounding vacuum medium as **infinite numbers of unseen spherical concentric shells with different constant value of stress in vacuum medium** around the center mass. In this way, each shell would represent different value of some constant “**Gaussian surface curvature**”. Also each shell represents different layer of “**Geodesic closed surface**”. The closer layer of the shells to the mass means the larger curvature of the Geodesic path, while the far away shells mean the smaller curvature of the Geodesic path.

Below are the diagrams which show the deviation of light ray path through curve space-time. In a) the bending of light ray path follow **the imaginary curve space of rubber sheet**, while in b) the bending of light ray path follow the Geodesic path of the Gaussian surface curvature. So we could see that **it is more rational for curved space-time with non-uniformity of the internal stress created in vacuum medium space, rather than the conventional curved space-time of empty space!**

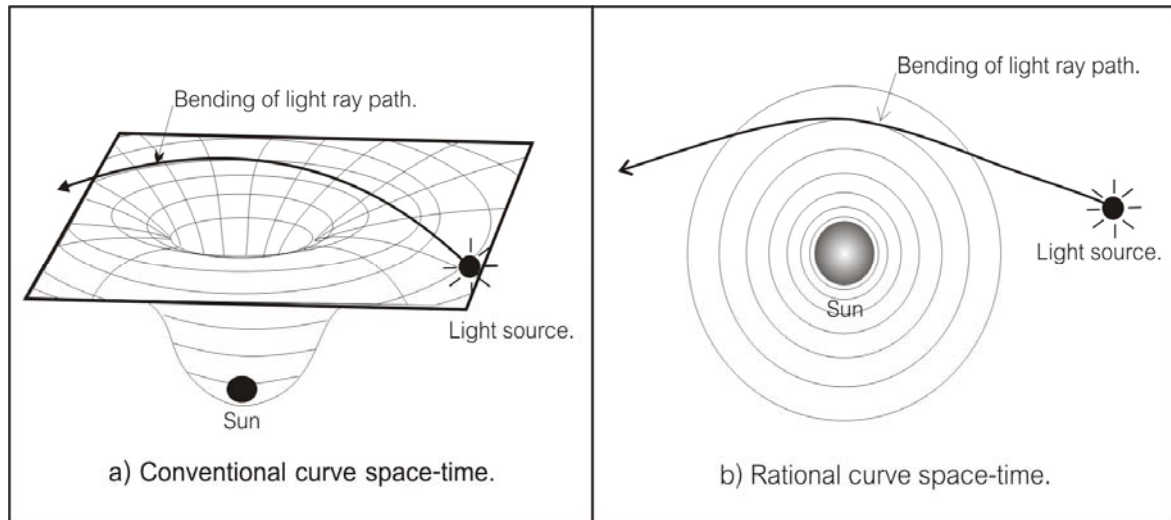

Figure 5 Light ray path through curve space-time.

For an example, we will show how the concept of “uniformity of the internal stress in vacuum medium space” **could explain “curved space” in GTR by using Schwarzschild exterior solution** below.

$$ds^2 = (1 - 2m/r) dt^2 - (1 - 2m/r)^{-1} dr^2 - r^2 (d\theta^2 + \sin^2 \theta d\phi^2) \dots (11).$$

It is the metric equation of line element (square of interval) of curve space-time surrounding a spherical body mass M . And we can approximately express it in rectangular coordinate (and may be called isotopic) [7] as below

$$ds^2 = (1 - 2m/r) dt^2 - (1 + 2m/r) (dx^2 + dy^2 + dz^2) \dots (12).$$

When there is no gravitating body ($M = 0$) equation (11) and (12) reduce to a flat space-time as below

$$ds^2 = dt^2 - dr^2 - r^2 (d\theta^2 + \sin^2 \theta d\phi^2) \dots (13), \quad ds^2 = dx^2 + dy^2 + dz^2 \dots (14).$$

Now consider the coefficient of time component g_{00} of (11) which is equal to $(1 - 2GM/rc^2)$. And we could see from (2) that the gravitational potential $\phi = GM/r$, so $g_{00} = -1/g_{11} = 1 + 2\phi/c^2$ [8]. When we compare g_{00} in (11) with g_{00} in (12) which is a flat space-time then we would see that **the additional term $2\phi/c^2$ is the additional energy aroused from the gravitational potential due to M** . Also this additional energy is greater near mass M , and it will be reduce to zero when r is infinite. Based on Vacuum medium space-time we could equally say that internal stress energy in vacuum medium is greater near mass M , while it will be reduce to zero when r is infinite. **Or we could say that the non-uniform of internal stress energy in vacuum medium mean the curvature in space around mass M !**

In conclusion we could say that **a three-dimension flat space-time is the space with uniform internal stress of vacuum medium in that space, while a three-dimension curved space-time is the space with non-uniform internal stress of vacuum medium in that space!** This is an understandable space-time, isn't it?

5) Modification of GTR. Up to now we have seen how the concept of vacuum mechanics (mechanism of vacuum medium) gives a better view of gravity, relativity and space-time. It let us to visualize and understand the mechanism of gravity, it gave us a more natural concept of space-time and it let us understand clearly what the curved space-time is. And because those things which we just mentioned are the essential part of GTR, so if we want a complete GTR we have to improvement it by using this new better concept.

5.1) Einstein tensor is vacuum tensor. Let's look again at Einstein field equation (3) below

$$G_{\mu\nu} = kT_{\mu\nu} \quad \dots (3).$$

The formula said that Einstein tensor $G_{\mu\nu}$ is curvature tensor $R_{\mu\nu} - (1/2)g_{\mu\nu}R$, which provides a complete description of space-time curvature. And it **is equal to** energy-momentum tensor $T_{\mu\nu}$ of all matters and energy involved (except the gravitational energy created by the matters itself) in the system. But **there is no way to deduce the connection** (between the two parts) **from more fundamental principle** [9]!

When considering it in detail, the above **space-time geometry $G_{\mu\nu}$ is a geometry of "nothing"** that is; **it is the geometry of an empty vacuum space.** So it is difficult to visualize how to deal with the tensor of "nothing" which is unphysical. In the real world we normally use tensor for solving the problem with something which is physical such as electromagnetic field, fluid or solid materials. **It is Einstein's genius that he could imagine** (guided by Mach's principle and the principle of equivalence) **how to link an energy-momentum tensor** (physical tensor) **to describe the abstract geometry of space-time!**

But when we consider the energy-momentum tensor $T_{\mu\nu}$ in the view of the whole universe, we would found that it consists of all the matter and energy that irregularly distributed across the universe; **it is not a continuous physical medium which contains all the necessary information for Einstein tensor.** So he had designated a new kind of material field with mass, energy and momentum densities at each point in the system; that is the energy-momentum tensor required.

Now we have learned above that **actually space-time geometry is the physical geometry of vacuum medium.** And this vacuum medium is the main part of mass (energy) that pervaded across the huge universe. Then all the observable matters of galaxies, stars, dust clouds etc. are the minor part that are immersed in the sea (of uniform distribution) of vacuum medium through out the whole universe. **Then Einstein tensor which originally was an imaginary becomes a real tensor of physical geometry of space-time.** So we could say that **Einstein tensor is vacuum medium tensor** (tensor of vacuum medium space)!

5.2) Return of cosmological constant. Someone who familiar with GTR would found that the total matter and energy existed in the form of energy-momentum tensor $T_{\mu\nu}$, which is the source that create the curvature of space-time **does not include gravitational energy** (which created form the total matter and energy) **itself. So it means that the total energy in the system is not conserved!** This is the crucial weak point of GTR.

And to solve the problem, it was proposed a quantity which play the same role as a gravitational potential; a 4x4 pseudotensor $t^{\mu\nu}$ (the gravitational potential energy of the field) by adding it to $T_{\mu\nu}$, to assure the energy and momentum to be conserved. How ever $t^{\mu\nu}$ is merely a pseudo-tensor, **it does not have a convincing physical presence or absence** [10].

Armed with vacuum medium space, it is easy to solve the problem. We start with **general form** of the full field equation with **cosmological constant** Λ as (15) follow.

$$R_{\mu\nu} - (1/2)g_{\mu\nu}R - \Lambda g_{\mu\nu} = kT_{\mu\nu} \dots (15), \quad R_{00} + (1/2)R = kc^2 (\rho_0 + \Lambda/kc^2) \dots (16).$$

Then after rearranging (15) and write out the 00-component as show in (16), where T_{00} was replaced by $\rho_0 c^2$ (ρ_0 = mass density). So reference to (16), **Λ functions as a constant mass density of vacuum medium energy**, and acting as the “ambient mass” which **spread through out space** [10]!

Einstein first introduced Λ to act **as a repulsive force** in the field equation to counter the gravity for a static universe. But after knowing that actually the universe is undergoing an expanding, he discarded it while said that “... the biggest mistake I ever made”. Nowadays it is assumed to be ‘very small’ so it will be still including in most treatment of relativistic cosmology [11]. Anyway even the universe was found to continue expanding, but **what is the cause which made it to expand against the gravity? Here the author proposes to use Λ as the ambient mass of vacuum medium energy** which is the energy source for repulsive force mentioned.

In VMTE, we have said that the **ambient mass** of vacuum medium energy is so dilute. So it is insignificant on a planetary or local galactic scale, but **it will be dominant on the cosmic scale** (because the huge volume of the universe). As for an example, we could see it from Schwarzschild exterior solution derived including Λ [7] as below

$$ds^2 = \left(1 - 2m/r - \Lambda r^2/3\right) dt^2 - \left(1 - 2m/r - \Lambda r^2/3\right)^{-1} dr^2 - r^2(d\theta^2 + \sin^2\theta d\phi^2) \dots (17).$$

Comparing (11) and (17) we could see that the effect of Λ term on the field surrounding the central mass M would increase with the size of the region considered. Hence, since the motion of the planets are actually given with great accuracy by (11), we can conclude that **Λ is in any case small enough not to produce appreciable effects within a region of the order of size of the solar system.** And we can calculate its value by setting Λ/kc^2 term in (16) equal to mass density of vacuum medium $\rho = 23.3 \times 10^{-28} \text{ Kg./m}^3$ (from the last paragraph of section 6.1). Then **what we got is $\Lambda = 4.34 \times 10^{-53} \text{ m}^{-2}$** which is very small indeed!

Finally **we have solved the problem and fulfill the field equation (3)** by just add vacuum medium to energy-momentum tensor in term of Λ . **Actually the final result is just the returning back to equation (15)**. What we have done is to give the appropriate meaning of Λ . Or we equally say that equation (15) is not just a more general field equation, but it is more rational than (3). And this is what we say that **it is the returning of the cosmological term Λ !**

6) Solution to the crucial problems in GTR. Let's start with a famous physicist S. Chandrasekhar (1980) word (when he had talk about problems in GTR) as "The element of controversy and doubt, that have continued to shroud the general theory of relativity to this day, derived precisely from this fact, namely that in the formulation of his theory Einstein incorporates aesthetic criteria; **and every critic feels that he is entitled to his own differing aesthetic and philosophic criteria.** Let me simply say that I do not share these doubt; and I shall leave it at that" [12]. **In this paper the author doesn't dare to do some thing like that,** the only aim is to complete GTR. Then this will make GTR to consistence with QMT and **paving the way to the theory of everything** as mentioned in the original paper!

6.1) Problem with speed of gravity wave. Einstein had showed that the existence of gravitational wave radiation is a natural consequence of the GTR. By considering the case of weak field equation (space-time curvature is small), he got a linear wave equation (of gravity) which is transverse wave traveling with velocity of light resemble to electromagnetic wave.

But, why gravity wave traveling with speed of light, it is just his guessed that it would be the same speed [13]. For electromagnetic wave it is obvious that we could prove that it traveling with velocity of light by using Maxwell equations, while we could not do the same thing with gravity wave! This may be the reason that most of the text books about GTR tried to avoid talking about it.

According to GTR, we known that **space-time is just an empty space without any physical entity so it is very difficult and even impossible to explain how gravity wave could propagate without some thing act as the medium.** (Indeed there is no exception for every kind of waves, and in CEMT we have shown that it is unreasonable for electromagnetic wave traveling without vacuum medium.) Some author such as I.R. KENYON [8] who has an insight; he tried to explain gravity waves via stress-strain relation of space-time. He said that **"gravitational waves are quite simply the vibration of space-time itself"**. Unfortunately we could not easily to visualize how space-time (which is just an empty space) could act as the mechanism of wave!

Instead if we accept the vacuum medium concept then it is easy to understand that **gravity wave is just the vibration (mechanism) of vacuum medium which is the same thing as electromagnetic wave.** Of course we must not expect to get everything for gravity the same thing we do with electromagnetism. This is obvious because the source of gravity is different from one of electromagnetism; **that is normal masses could not create all phenomena as electrons do!**

Now let us explore some more detail for gravity wave by using the same concept as of electromagnetic wave

$$F = G \frac{m_1 m_2}{r^2} \dots\dots (1), \quad F = \frac{1}{4\pi\epsilon_0} \cdot \frac{q_1 q_2}{r^2} \dots\dots\dots (13).$$

(15)

By considering equation (1) for gravity and (13) for electrostatic, we would found that **both are the result of the same attraction force arisen in vacuum medium** between two pieces of mass. The only difference between them is that while the first one is a weaker force (normal gravity) due to the neutral masses, the second is stronger force (black hole force) due to charged masses. So **both of the two constants G and $1/4\pi\epsilon_0$ are the same property i.e. the internal stress of vacuum medium!**

Next, how could we find magnetic field for gravity which was called **gravitomagnetic field** [14] or **cogravitational field** [15]? We know that the flowing of electric current create magnetic field around the carrier wire, but how **could we find mass current to create gravitomagnetic field?** Actually we know that a single moving electron also create magnetic field. (Note that when an electron is moving, it will rotate and drag surrounding vacuum medium creating magnetic field as explained in CMET.) Then **a rotating (moving or not) sphere of mass should also create gravitomagnetic field!**

And show below is the formula for cogravitational field K (mentioned above) which was generated from a rotating sphere of mass moving with constant speed [11'],

$$K = \frac{v \times g}{c^2} \dots (14), \quad \text{where} \quad g = G \frac{m(1 - v^2/c^2)}{r_0^3 [1 - (v^2/c^2) \sin^2 \theta]^{3/2}} \cdot \vec{r}_0 \dots (15).$$

While K in (14) corresponds to in B (16) and g in (15) corresponds to E in (17) for a point charge moving with constant speed as below

$$B = \frac{v \times E}{c^2} \dots (16), \quad \text{where} \quad E = \frac{q(1 - v^2/c^2)}{4\pi\epsilon_0 r_0^3 [1 - (v^2/c^2) \sin^2 \theta]^{3/2}} \cdot \vec{r}_0 \dots (17).$$

By comparing (15) and (17), **what we got is** that G correspond to $1/4\pi\epsilon_0$ or $\mu_0 c^2 / 4\pi$.

Nowadays physicists try to find earth gravitomagnetic field according to reference [10]. They explained that gravitomagnetic field is the manifest of the dragged of (empty) space around the rotating mass and proportional to its angular momentum. But **it is difficult to visualize how the empty space could be dragged!** So it is more reasonable for the concept of vacuum medium, and for the author opinion, magnetic field is the same thing as gravitomagnetic field. So **the main part of earth magnetic field is the gravitomagnetic field** as mentioned in original article [1].

Finally we will try to find mass density of vacuum medium energy as mentioned in section 5.2. Referenced to the formula (m) in the derivation of Maxwell equation of CEMT, this was rewrite as equation (18) below,

$$c = \sqrt{M/\rho} = 1/\sqrt{\mu_0 \epsilon_0} \dots (18). \quad c^2 = k/4\rho = 4\pi G / (4\pi G/c^2) \dots (19).$$

(Where c is the velocity of light, M (elasticity) = $\frac{1}{4}k$ (twist modulus), ρ = mass density, μ_0 = permeability and ϵ_0 = permittivity of vacuum medium.)

Replacing M with $k/4$ and ε_0, μ_0 in term of G in (18) what we got is (19). Then comparing the second and third terms of (19) **we will get $\rho = \pi G / c^2 = 23.3 \times 10^{-28} \text{ Kg.} / \text{m}^3$ which is mass density of vacuum medium energy!** Also we could found from (19) that **the twist (shear) modulus of vacuum medium is $k = 4\rho c^2 = 6.3 \times 10^{-10} \text{ N} / \text{m}^2$** which is very low!

6.2) Some other remaining problems. There are many problems involved with GTR and below are some of the well known problems which could be solved using **vacuum mechanics** concept!

a) Missing masses and dark matter problem. One of the obvious problems about the rotating galaxies is their missing mass which was calculated from their rotating speed. Also there is missing mass for forming of galaxies into cluster of galaxies]. It was calculated that **the missing mass is 10 – 100 times the total amount of visible matter in the galaxies** [16. This missing mass was though to be the invisible dark matter, but no one knows what it is. Armed with the concept of vacuum medium, it is easy to see that **vacuum medium energy is the missing mass!** And when we compare them in term of mass density, it is the ratio >20:1 (see the last paragraph of section 7.1).

b) Mysterious magnetic field in galaxies. Magnetic field with strengths of $1 - 10 \mu\text{G}$ is widespread in the cosmos – in galaxies extended radio sources and in cluster of galaxies [17]. **And according to the reference;** “most of the cosmological models have been devoted to explain the amplification of an initial seed field by dynamo action in spiral galaxies. Also our understanding of magnetic field in spiral galaxies is very limited”.

“ An observation which we believed is highly significant is that for many nearby spiral galaxies the measured interstellar magnetic fields falls off much more slowly with radius than the matter density, i.e. in the outer parts of such galaxies the magnetic stress become comparable to gravity. Not only is this hard to understand in theoretical modeling, but it is taking place at distances where the rotation curve is flat and the flatness is usually interpreted as evidence for the presence of a halo of dark matter”.

The above paragraph has explained the magnetic field pattern that occurred in the rotation spiral galaxies, but we still could not understand why it is some thing like that. Armed with the concept of vacuum mechanics, it is easy to see that this is the appearance of the rotational stress of vacuum medium around the rotation of spiral galaxies! The reason is as mentioned in the above section that a big rotating mass will drags the surrounding vacuum medium with it. **And the rotational stress occurred in vacuum medium around is the manifest of the created magnetic field!**

c) Reinterpret equivalence principle. In STR, Einstein used principle of relativity as the main tool, which state that “physics in a uniform moving inertial frame is the same as physics in a rest one”. This is possible if space-time is an empty one, because any reference frame has an equal footing. But in CSTR, **based on the existence of the privileged reference frame of vacuum medium space-time**, this is no longer possible! So we have to reinterpret the principle of relativity as **“physics is equivalent referenced to the privileged reference frame of vacuum medium”**. In the same way Einstein has used principle of equivalence in GTR as the main tool, and which state that physics in a uniform acceleration frame is the same as physics in a free falling (in a uniform gravitation field) frame. So we have to reinterpret the principle of equivalence as **“physics is equivalent referenced to the privileged reference frame of vacuum medium”!**

d) Gravitation time delay. We know that in STR there is no explanation why a moving observer has a time dilation. And in the first section we have explained that **actually the conventional time dilation is just the slowing of the measuring clock** (due to the slowing of the moving clock mechanism). For GTR there is also no explanation why an observer in a stronger gravitational field has a time dilation (compare to observer in a weaker gravitational field or no gravitational field). **Based on the concept of internal stress in vacuum medium** (as explained in section 4.2), it is easy to explain why time dilation occur!

A measuring clock will run slower in stronger gravitational field (internal stress energy in vacuum medium) than the weaker one. This is because the bigger resistance of gravitational field energy, the more slows down the mechanism of the clock (compare to one in weaker gravitational field or no gravitational field). **This is a rational and understandable explanation of what was called “time dilation”!**

7) Vacuum medium universe – a better view of our universe. The most interesting application of Einstein field equation (3) is that it was used to describe our universe; the story of cosmology. **There are several weak points about the assumption for developing model of the universe and also the problem about the model itself.** In section 5.1 we have shown that Vacuum tensor is a better view for Einstein tensor. Here we will show that Vacuum medium universe (the universe composes with vacuum medium) is a better view of the universe.

7.1) Fulfilling the cosmological principle. While the relativity principle was the foundation of STR and the equivalence principle provide the physical basic for GTR, in cosmology **cosmological principle was introduced to let the field equation manageable.** Note that the first two principles were modified to get a more rational meaning under the concept of vacuum medium; now this new concept would **give the third principle to be a more meaningful.** Let's start with the amended and presently accepted form of the cosmological principle [10] which state that:

“The general overall features of the universe are the same relative to any local observer at corresponding epochs in the evolution of the universe”.

What does it means for the principle is to take **all the existing matters (galaxies and stars) uniformly distributed across the universe.** But we know that actually the matters are irregularly distributed, so how could we improve this weak point? Armed with the existing of vacuum medium, the principle could be strengthening. **The reason is because the total mass of vacuum medium energy (which uniformly distributed) is much more than that of the visible existing matters!** And when we compare them in term of mass density, it is the ratio >20:1 (see the last paragraph of section 7.4). So it doesn't matter how the tiny part of visible matters was distributed; **the total masses distribution in the universe is still uniform!**

7.2) What is a hypersphere? Under the cosmological principle, a simple model of the universe was tried to develop. **A positive (spatial) three- dimensional curve surface** called **“hypersurface”** which is embedded in a **(spatial) four- dimensional “hypersphere”** was introduced **to be a model of the universe.** To grasp it intuitively it was suggested looking at an analogy of the two-dimensional curve surface of our ordinary three-dimensional sphere balloon as the model of the universe. Anyway it is very difficult for anyone to visualize such an extra spatial dimension surface of the balloon as our universe, and then a question arises immediately: **is it any other simple view of the universe which we could understand it? Indeed the answer is yes, because the concept of vacuum mechanics helps us as below.**

First let us come back to see what actually the universe is: **basically the universe is composing of everything that existing i.e. galaxies, stars, dust and gas cloud.** All of these matters are interacting to each other by gravitational force; while the galaxies are flying apart from each other after originate from a single common point. From this point of view, **the universe will look like a simple expanding sphere ball (not just only the ball's surface)!** So we can use Newton gravitation law to develop the universe [17']. And indeed it was derived the Friedmann model of the universe by using Newton gravitation law in Newtonian cosmology [11'].

Now the question is, **why does a simple expanding sphere ball turn to be a four-dimensional** (not include time) **hypersphere** when it was involved GTR (which is just a relativistic gravitational)? To answer this question, we refer to Robertson – Walker metric equation which was derived from the concept of “four- dimensional hypersphere” below

$$ds^2 = dt^2 - R^2(t)[dr^2 / (1 - kr^2 / R^2) - r^2 d\theta^2 + r^2 \sin^2 \theta d\phi^2] \dots\dots\dots (20).$$

(Where R is the radius of the hypersphere, k = 1, 0 or -1 according to three models; closed, flat and open respectively.) Then we will compare it to the metric equation of “Einstein static universe” model, **which was derived from the spherically symmetrical static form of conventional space-time geometry [aw']** as below

$$ds^2 = dt^2 - dr^2 / (1 - r^2 / R^2) - r^2 d\theta^2 + r^2 \sin^2 \theta d\phi^2) \dots\dots (21).$$

Here we can see that when the term $R^2(t)$ in equation (20) was ignored, **then (20) is the same pattern as (21)!** Indeed in the reverse, equation (21) can be changed to the form of three-dimensional spherical surface which embedded in the four-dimensional Euclidean space (as shown in the reference); that is the starting point of Robertson – Walker metric equation. **In conclusion** we could see that **actually “the four- dimensional hypersphere” is just an ordinary four-dimension space-time sphere ball of vacuum medium in which all the visible existing matters was immersed inside; and this is our understandable universe!**

7.3) The origin of universe. Nowadays, main part of cosmologists believes in the hot big bang with inflation universe. **“But the universe is the ultimate free lunch”**, this is Stephen W. Hawking's word [5']. The mentioned universe was suggested to start out from the hot infinite dense singularity; then it had expanded with acceleration (inflation) up to the present universe. **The big problem is that where did the huge quantity of the increasing matter come from, it contradicts to Law of conservation of energy (mass)!** To solve the problem, team of experts in astronomy & astrophysics has proposed a new cosmological model called “quasi-steady-state model” [17'].

According to **the new theory “quasi-steady-state model”**, **the major development is that matter creation occurs with energy conservation.** Their thesis that matter is created and ejected in the form of quasi-stellar objects and matter in other forms from the nuclei of galaxies are the observational evidences. In summary the general equation of the theory was derived from the friedmann-Robertson-Walker model **by introducing a scalar field C.** The role of C - field is to act as **a negative energy and negative pressure for the effect of matter creation**, and the matter creation is to accelerate the expansion of the universe. **So there is no need a hot big bang with inflation scenario!**

By the way in this new model, it was explained that the existence of **near – black hole** in the center of galaxies **is an indication of the creation events have taken place**. And to visualize such events in physical terms, the suggestion conceptual explanation is from the basic fabric of space-time. They are well-used to thinking that particles creation occur in association with a transition that involves space-time in a physical way, not just as a passive medium in which particles are supposed to exist. **In graphic language, particle creation would be associated with an opening-up of space-time!**

For Vacuum medium space-time, we have mentioned early that the fabric structure of space-time was created out of vacuum medium energy. Or we could say that **vacuum medium is the raw material for constructing the fabric structure of space-time!** This means that at the starting moment, the universe is zero size (no space-time) there is no vacuum medium either. When the universe is expanding its size, vacuum medium must be increased for expanding the fabric structure of space-time. And when the universe is reducing its size, it means that vacuum medium is decreasing. **Then we could see that vacuum medium universe is possible without hot big bang and inflation universe!**

Note that actually vacuum medium is just the contraction (gravity) energy that try to encounter its expanding (please see detail in CEMT). **So if we think that the existing of vacuum medium as positive energy, and its intrinsic property (gravity) acts as negative energy, then the total energy of the universe is conserved!**

Finally we could see that vacuum medium universe and quasi-steady-state model **may be classified in the same group**. Both of them were created **without hot big bang and inflation!** In technical detail, vacuum medium energy in vacuum medium universe could be though as C-field in quasi-steady-state model. And in vacuum medium universe vacuum medium energy create space-time, while in quasi-steady-state model, particle creation would be associated with an opening-up of space-time. **So in the future when we combine both models together, we may get a more complete theory of our universe!**

7.4) Our universe is closed! According to the hypersurface model of the universe, it was divided to three types of space-time's curvature depend on the value of k in Robertson – Walker metric equation (20). First where $k = 1$, it represents **closed universe** or the universe with positive curvature (something look like the earth surface), second where $k = 0$, this will represent **flat universe** or the universe with zero curvature (something look like ordinary flat surface) and third where $k = -1$, it represents **open universe** or the universe with negative curvature (something look like saddle shape surface). For the first type of the universe, we have commented that it is very difficult to visualize **how it is in the real world**. Also we would found that the remaining two types facing the same difficulty!

Based on the concept of sphere ball of vacuum medium universe, it is easy to understand all three types of space-time curvature. As mentioned early that vacuum medium is uniform everywhere across the whole universe. **This doesn't mean that it make the universe flat**. The reason is because vacuum medium is just act as the background fabric structure of space-time (i.e. the ambient mass mentioned in section 6.1) which will **handle the internal stress energy** (gravitational potential energy) occurred within! So when we talking about the **mass density of the universe** we mean the **total energy** which **equal to the ambient mass plus the conventional mass (i.e. all the existing masses we are familiar)!**

According to the diagram shown below when the universe is close (where $k = 1$). **It means that the average mass density is higher near the center and lower in the area far away**, and it was shown by the spacing between the concentric rings (actually they are concentric shells). The closer spacing means the higher mass density while the wider spacing means the lower density. Next when the universe is flat (where $k = 0$), **its means that average mass density is uniform through out the whole universe**. Lastly when the universe is open (where $k = -1$), **this means that the average mass density is higher near the rim and lower when approaching the center**. So now we could see that it is easy to visualize whether the universe is curved or not by using the new concept; that is **the uniformity of mass density is the indicator of space curvature!**

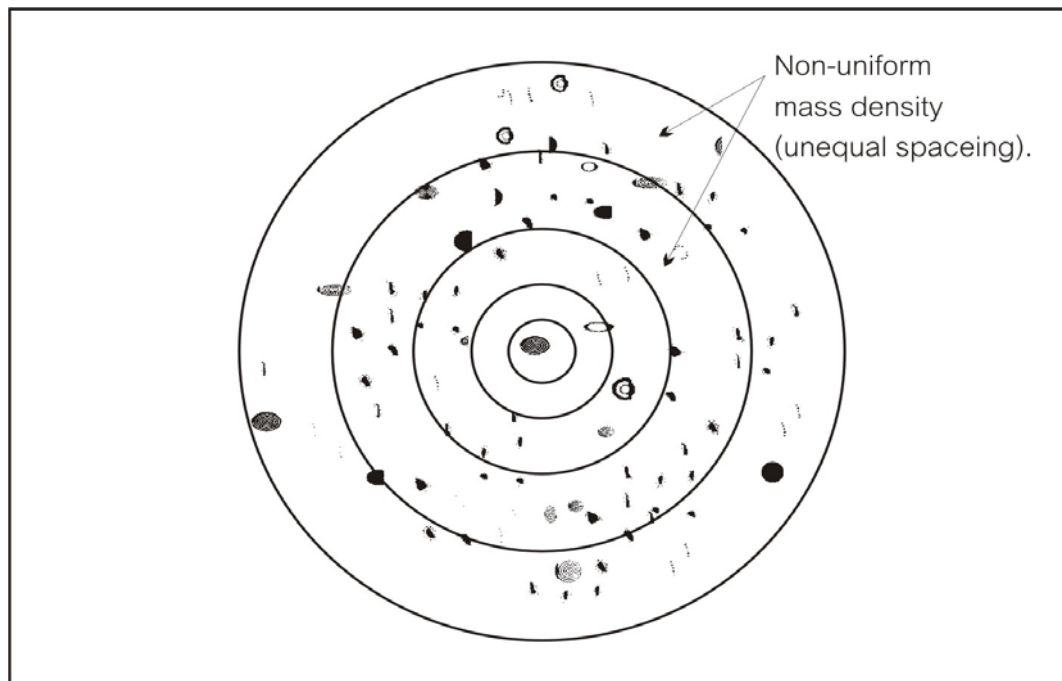

Figure 6 Curvature of Vacuum medium universe.

Now we come to the most popular question; whether our universe is close or open? Does it will expand forever, or at a certain time it will collapse back to the beginning again? Up to now, cosmologists found that **the universe seems to expand to the cold dead end rather than contract back to the hot big crunch singularity!** This is because the observed existing mass density was found to be around $\rho_0 = 10^{-28} \text{ Kg./m}^3$. This is far from the critical density of mass $\rho_c = 60 \times 10^{-28} \text{ Kg./m}^3$ [10'''] which was needed to close the universe. (Note $\rho > \rho_c$ means closed universe, $\rho = \rho_c$ means flat universe and $\rho < \rho_c$ means open universe.)

Anyway, the calculated critical mass density above was made on the assumption of zero value of cosmological constant. **Here we will recalculate by including the cosmological constant** that was found in section 5.2 above by using formula (22) [8'''] below

$$\rho_c = (3H^2 - c^2\Lambda) / 8\pi G . \dots (22). \quad (\text{Where } H \text{ is Hubble constant.})$$

After calculation what we got is the **new calculated** value of critical mass density (A) $\rho_c = 36.7 \times 10^{-28} \text{ Kg./m}^3$. And from the end part of section 6.1 **we found that the mass density of vacuum medium** $\rho = 23.3 \times 10^{-28} \text{ Kg./m}^3$, which is the unseen ambient mass of space-time. When it was included with the observable existing mass density $\rho_0 = 10^{-28} \text{ Kg./m}^3$ plus its equal amount of gravitational potential energy within itself, then we will get a **new existing mass density** (B) $\rho_0 = 25.3 \times 10^{-28} \text{ Kg./m}^3$.

Now we could see that, based on concept of vacuum medium, **the new total mass density (B) is close to the new critical density (A)**. So these would give us a new possibility that **our universe is no need to be only the open universe. It may be a flat universe or a closed universe** depending on the accuracy of the parameters involved.

And if the observable mass density is about 30% of the critical density ($\rho_c = 60 \times 10^{-28} \text{ Kg./m}^3$) which was reported lately [10"], that is about $18 \times 10^{-28} \text{ Kg./m}^3$. Then we will get a new bigger value of (B), that is $\rho_0 = 43.3 \times 10^{-28} \text{ Kg./m}^3$. So finally we will get $\Omega = \rho_0 / \rho_c = 43.3 \times 10^{-28} / 36.7 \times 10^{-28} = 1.2$, which means that our universe is closed!

Anyway, according to the concept of vacuum medium that space-time was created from vacuum medium energy. **Then whether the universe is flat or open, this would mean that it will expand forever. And what will follow is the infinite amount of mass (energy) would be created!** But that is crazy, so in this sense **the only possible choice is that the closed universe**, isn't it?

8) Conclusion. Up to now we have seen how GTR was improved by adding it with rational philosophical idea (which tell how the theory work); **the mechanism for relativistic mechanics** i.e. **the mechanism of vacuum medium** (or vacuum mechanics)! Indeed it is the same mechanism used in improving STR and extends to cover GTR. (Note that GTR is extended from STR by including gravity.)

The crucial things which **vacuum mechanics** give to GTR are the mechanism of gravity, physical space-time, physical meaning of curve space curvature and how gravity wave propagates etc. All these things **could not be understood in the conventional GTR**, armed with the new concept, it is easy to visualize and explainable!

Comparing with STR we would see that the topic in GTR is much wider and more complicate, so we could not go into more detail in this paper. For example, the topic such as conventional black hole topic was not mentioned here. Indeed the author felt that **it is unconvincing for the huge massive star to collapse into a mystic black hole in which we could not understand how it is something like that!** (Note that even Einstein himself did not believe in the black hole [18].)

By the way, we know that there is one big problem to combine GTR with quantum mechanics (QMT) in order to get successful **quantum gravity**. Then this modified theory i.e. Completed Einstein general theory of relativity (CGTR) would provide a better way to the desired theory!

Lastly, we could see that what was written in this paper is a short one, and it is not fully mathematical rigor. What we have done **is just enough to give the new idea to the readers with some confidences**. So what was left here should be the work of people who are involved in the matter to complete it **for the virtue of academic merit and the progress of our world's knowledge!**

9) References.

(Precaution; Several GTR text books with different authors were used as the reference and each author used different pattern and different notation for the same formula. Here in this paper, the author has made some change of the original pattern and notation for the readers convenient, so please be careful!)

- [1] By Nimit Theeraleekul, now present in www.vacuum-mechanics.com.
- [2] Michael de Podesta, "Understanding the Properties of Matter", p.126-127 and p.246-247.
- [3] Richard P. Feynman, Robert B. Leighton and M. Sands, "The Feynman Lectures on Physics" Vol. 2. p. 4.7-4.10.
- [4] Reese, Ronald Lane, "University physics", p.264-267.
- [5] Stephen W. Hawking, "A Brief History of Time", p.25. For [5'] p.136.
- [6] Richard P. Feynman, "Six-not-so-easy pieces", p. 123.
- [7] Richard C. Tolman, "Relativity Thermodynamics and Cosmology", p.334-338. For [7'] p.202-205.
- [8] I.R.KENYON, "General Relativity", p.45. For [8], p. 5 and p.124-143. For [8"] p. 158.
- [9] Richard P. Feynman, Fernando B. Morinigo, William G. Wagner, "Feynman Lectures on Gravitation", p.135. For [9'] p.xxiii.
- [10] Richard A. Mould, "Basic Relativity", p. 336-338. For [10'] p. 393-394, for [10"] p.405-406, and for [10""'] p. 422.
- [11] Ray d'Inverno, "Introducing Einstein's Relativity", p.171-173. For [11'] p. 310-312.
- [12] Bernard F. Schutz, "A first course in General Relativity", p.197.
- [13] Richard P. Feynman, "The Character of Physical Law", p.53-54.
- [14] Ignazio Ciufolini and John A. Wheeler, "Gravitation and Inertia", p.1-9.
- [15] Oleg D. Jefimenko, "Causality Electromagnetic Induction and Gravitation", p. 83-88.
- [16] Robert Resnick, David Halliday, Kenneth S. Krane, "Physics" Volume 1, Fourth edition, p.361-363.
- [17] F. Hoyle, G. Burbidge and J. V. Narlikar "A Different Approach to Cosmology, From a static universe through the big bang towards reality", p.321-325. For [17'] p.14. And for [17"] p.189-196 and p. 311- 320.
- [18] Tian Yu Cua, "Conceptual Development of 20th Century Field Theories" p.119.

.....

